

General Specifications

Model UP750 Program Controller (with Custom Computation)



GS 05E01B02-01E

General

Model UP750 Program Controller is an intelligent, micro-processor based program controller that has the capacity of 300 program patterns, powerful control capability, custom computation function and a user-friendly display. The UP750 has many control modes as standard, and all these functions such as program setting function, control function, control computation function, signal computation, etc. can be configured by using the keys on the front panel. The instrument includes eleven types of predecided control strategies including cascade, temperature/ humidity, and more in single or dual loops. Auto-tuning control, an overshoot suppressing function "SUPER" and a heating suppressing function "SUPER 2" are standard.

Main Features

- Extra-large digital display allows the indicated values to be read even from along distance. LEDs of 20mm height are used for the process variable display. This is a five-digit display for higher resolution.
- User-friendly full dot LCD display. Not only the target setpoint and control related parameters, but also a program pattern, deviation trend record or an analogue bargraph of control output value can be displayed on it.
- Huge capacity of 300 program patterns / 3000 segments. Applicable to a wide range of heat treatment, textile, environmental chamber and testing application.
- Eleven type of control function, including single-loop control, cascade control, loop control with PV auto-selector, and custom computation function, enabling the operator to start control operation immediately after simply entering the settings.
- The program pattern-2 retransmission function outputs a program pattern (control setpoint) by way of the retransmission output. This function is used in combination with retransmission output setup parameter RET 1 or RET 2, for which target setpoint-2 (SP2) should be selected, and is used for pattern transmission to another instrument (available for UP mode 1, 2, or 6).
- Custom Computation capability, which allows users' own configuration for signals, enables them to realize such functions as complicated computation for input compensation or sequence logic for input/output. ("PC-based Custom Computation Building Tool <model name: LL200>" is necessary to use this function.)
- Universal input and output enable users to set or change freely the type of measured inputs(thermocouple, RTD, or DCV), measurement input range, type of control output(4 to 20 mA current, voltage pulse, or relay contact) etc. the front panel.
- Equipped with seven contact inputs and outputs each, which are further expandable up to 23 inputs and outputs each by adding contact I/O signal expansion modules.
- Various communication function are provided. Communication is possible with personal computer, programmable logic controller, and other controllers.

UP750



UP750E

"E" indicates with the model with expanded functions.

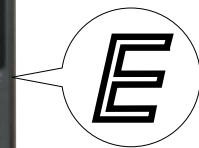

Functional Specifications

Program Setting Function

"Program setting" allows the setting of a setpoint versus time. The instrument can store program patterns and change the pattern according to the operating status. One program pattern consists of several broken line (segment). The length of each segment can be set by segment time. Users can also configure the number of Repeats, Start/Stop, event outputs, etc.

- Program pattern setting capacity: 300 maximum
- Number of segment/pattern: 99 maximum
- Number of segment: 3000 maximum (sum of segments for all program patterns)
- Number of event: 4000 maximum (sum of events for all program patterns)
- Number of program repeat time: 0 to 999, or unlimited repeats.
- Segment time: 0 minute 0 s to 59 minute 59 s, or 0 h 0 minute to 59 h 59 minute.
- Mode of program pattern operation:
Start (RUN), stop (RESET), paused (hold), advance, can be executed by an external contact or instrument operation.
- Switching between program patterns:
Achieved by contact input or instrument operation.

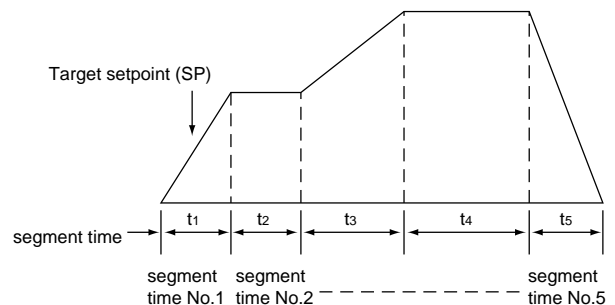

Example of program pattern

Wait Function

The function to delay the progress of the program pattern when Process variable (PV) does not reach the change of the target setpoint (SP). The wait function has two parameters: a wait zone and a wait time.

Wait zone is a range of the deviation, and wait time is the time to wait for PV to reach the wait zone. If PV reaches the wait zone within a certain time (wait time), then the program will advance to the next segment. If PV does not reach the wait zone even after the wait time passes, then the program will eventually advance to the next segment.

Wait time: OFF, 0 minute 1 s to 99 minute 59 s or 0 h 1 minute to 99 h 59 s.

Wait zone: 0 to 10 % of measured input range width.

UP mode and Program Setting Function

UP mode with one channel of control: Single-loop control, Cascade primary-loop control, Loop control with PV switching, Loop control with PV auto selector, Loop control with 2 universal inputs switching, Cascade control, Cascade control with 2 universal inputs. Note that Program pattern setting function is only available with the cascade primary-loop when Cascade control with 2 universal inputs are used.

UP mode with two channels of control: Dual-loop control, Temperature and humidity control. The following functions are common to dual program setting functions ("Program pattern RUN/RESET", "The total number of program segment") and "Segment time".

Program Setting Function and PID Parameters Switching

Controller can switch between PID parameter sets as a program pattern progresses.

Segment PID selection: PID-parameter numbers being used can be selected on a segment basis.

Zone PID selection: PID parameter sets are selected depending on the value of the applied PV input. Either the reference point method (reference point: a setpoint for switching between PID parameter sets) or the reference deviation method is used for the switching.

Reference point method: Divides the measurement input range into as many as seven zones using a maximum of six reference points, and switching between PID parameter sets is done on a zone basis.

Reference deviation method: Switches between PID parameter sets depending on whether the control deviation (DV) is within the given reference deviation or exceeding the deviation. This method has priority over the reference point method during operation.

Time Events

Time event is selected based on time in the program pattern

Number of time events: 8 points max. per segment (Max. 8 points for per segment the instrument with two control channels)

Time event display: 4 points (TME1, TME2, TME3, TME4)

Time event setting point: Start and duration (user settable)
Setting time: 0 minute 0 s to 99 h 59 minute.

PV Events

PV event is the PV/DV alarm function which is configured in relation with the program pattern.

Number of PV event: max. 8 points per segment

PV event display: 2 points (PVE1, PVE2)

The status of all the setting events can be seen in the operating display.

Event types: PV high limit, PV low limit, Deviation high limit, Deviation low limit, Deenergized on deviation high limit, Deenergized on deviation low limit, Deviation high and low limits, High and low limits within deviation, Deenergized on PV high limit, Deenergized on PV low limit, SP high limit, SP low limit, Output high limit, Output low limit.

Configurable ranges of PV events:

PV alarm: -100 to 100% of measured input range

DV alarm: -100 to 100% of measured input width

Alarm hysteresis: 0.0 to 100% of measured input range width

Instrument Alarm Functions

The instrument alarm function outputs PV, deviation, SP, and other alarm without regards to the program pattern. Controller has four instrument alarm outputs.

Alarm types: PV high limit, PV low limit, Deviation high limit, Deviation low limit, Deenergized on deviation high limit, Deenergized on deviation low limit, Deviation high and low limits, High and low limits within deviation, Deenergized on PV high limit, Deenergized on PV low limit, SP high limit, SP low limit, Output high limit, Output low limit.

Alarm setting range:

PV/SP alarm: -100 to 100 % of measured input range.

Deviation alarm: -100 to 100 % of measured input range width.

Output alarm: -5.0 to 105.0 % of output value.

Alarm hysteresis: 0.0 to 100.0 % of measured input range width.

Stand-by action: Stand-by action can be set to make PV/ deviation alarm OFF during start-up or after SP change until SP reaches the normal region.

Other alarm actions:

Sensor grounding alarm: Detects sensor deterioration and outputs an alarm.

Fault diagnostic alarm: Input burnout, A/D conversion error, RJC error

FAIL output: Abnormality in Software, Abnormality in Hardware

Number of Instrument Alarm Settings: 4 points

Number of Instrument Alarm Outputs: Max. 4 points

One of PV alarm/Deviation alarm, Fault diagnostic alarm, Sensor grounding alarm and Fail output can be output with contact output.

(Note): Refer to the later "Contact Outputs" in Hardware Specifications.

Event Output Functions

Output contact: Max. 7 points of contact output can be used to output the event/alarm (See 'Contact output')

The following number are pre-configured as an initial setting upon shipment.

Time event: 4 points

PV event: 2 points

Instrument alarm: 1 point

Max. 23 points outputs are available when Expansion Digital I/O connected.

Time events, PV events and Instrument alarm can be assigned for any contact output. Event and alarm status can be read by communication.

● Control Functions

UP mode

The following types of basic control structure can be set as the UP mode by the user.

- Single-loop Control (UP mode 1): The most simple and basic control function.
- Cascade primary-loop control (UP mode 2): Output tracking function and cascade control logic are provided. Suitable for the primary- loop cascade control.
- Cascade control (UP mode 4): Dual control functions. Whole Cascade control can be executed with a single instrument.
- Loop control with PV switching (UP mode 6): Two measured inputs are switched for control depending on the status of contact input or measured input.
- Loop control with PV auto-selector (UP mode 7): Two measured inputs are automatically selected for control with a high, low, average, or temperature-difference value selector.
- Dual-loop control (UP mode 11): Dual control function is available in a single instrument to control two loops.
- Temperature and Humidity control (UP mode 12): Temperature control and Relative Humidity control are available in a single instrument.
- Cascade control with two universal inputs (UP mode 13): Cascade control with using two universal measured inputs.
- Loop control with PV switching and two universal inputs (UP mode 14): Loop control with PV switching and two universal inputs available as measured inputs.
- Loop control with PV auto-selector and two universal inputs (UP mode 15): Process variable for loop control is automatically selected from two or three measured inputs by an internal selector, using two universal inputs and an auxiliary analog input. When two universal inputs are configured as measured input, auxiliary analog input can be used for a remote setpoint input.
- Custom computation control (UP mode 21): Can be provided by the user using the optional LL200 custom computation building tool.

● Control Computation Functions

In each UP mode, the following control types can be selected.

Continuous PID control, Time-proportional PID control, Relay ON/OFF control, Heating/Cooling control.

- Target setpoint and PID parameter: Maximum eight sets of target setpoint and PID parameters can be set and stored in a instrument. For Cascade control and Dual-Loop control type, eight sets for each main and slave are available.
- Auto-tuning: standard
 - Possible to activate auto-tuning for both loops of Cascade control, Dual-loop control and Temperature and humidity control.
- “SUPER” function: Overshoots generated by abrupt changes in the target setpoint or by disturbances can be suppressed.
- “SUPER 2” function: This function stabilizes the state of control that is unstable due to hunting, etc.

without requiring any change in PID constants, when the load and/or gain varies greatly, or when there is a difference between the characteristics of temperature zones.

Preset output function: When the instrument is in reset mode, measured input is burnout, or abnormality is found in an input circuit, users' preconfigurable preset value is output as a control output.

Control cycle time: Each cycle time can be selected under the following conditions

- 100 ms: Available when model code is UP750-0 □.
- 200 ms: Available with UP750-5 □, or when the amount of computation module of Custom computation function is less than 30.
- 500 ms: Available when the amount of computation module is 50 or more.

(Set value on shipped from the factory: 200 ms)

Operation Mode Switching

(Note:Communication enables all the following mode switching to be executed.)

AUTO/MANUAL switching: Bump-less switching is available. Switching between AUTO and MANUAL mode can be realized by instrument operation or by external contact, and external contact switching has priority to instrument operation.

RUN (PRG)/STOP (RESET) switching: Switching can be realized by the front key or external contact, and external contact switching takes priority to the front key. Bump-less switching for RESET to PROG is available. In PRG mode, control computation is activated. In RESET mode, control computation ceases and preset output value is output as a control output, while other functions operates normally.

CASCADE/Local SP switching: Switching can be realized by instrument operation or external contact, and external contact switching takes priority to instrument operation. Available when UP mode is set to “Cascade control” .

Control Parameter Setting Range

Proportional Band: 0.1 to 999.9%
0.0 to 999.9% (for heating/cooling PID control), 0.0% available for ON/OFF control.

Integral time: 1 to 6,000 s, or OFF(for Manual reset)

Derivative time: 1 to 6,000 s, or OFF

ON/OFF control hysteresis: 0.0 to 100.0% of measured input range width

Preset output value: -5.0 to 105.0% of output range (0mA or less cannot be output)

Output limiter:

Setting range: -5.0 to 105.0% for both high and low limits.

However “low limit setpoint < high limit setpoint” must be satisfied.

In case of heating/cooling PID control, upper limiter for heating and upper limiter for cooling.

Shutdown function: In manual mode operation, up to approx. 0mA can be output. (For 4 to 20 mA control output only)

Rate of change limiter for output: OFF, or 0.1 to 100.0%/s
Dead band for heating/cooling control: -100.0% to 50.0% of output value

● Configuration of Input/Output Signal

Measured Input Computations

Bias (-100.0 to 100.0%), First lag filter (OFF, time constant 1 to 120 s), Square root extraction (for voltage input only, Input low cut 0.0 to 5.0%), 10-segment line linearizer/bis function, relative humidity calculation for wet/dry bulb (for Temperature & Humidity control type only)

Auxiliary Input Computations

Bias (-100.0 to 100.0%), Filter (off, time constant 1 to 120 s), Square root extraction (Input low-cut 0.0 to 5.0%).

Custom Computations

LL200 Building tool is necessary for using Custom computation function.

Combining computation function modules allows such functions as user configuration of input/output signals, operation mode switching via discrete input, status output via discrete output, and so on.

Computation function module: Addition/substruction/multiplication/division, Processing absolute value/reciprocal, Selecting maximum/minimum/average, Keeping maximum/minimum value, Keeping value, Rate of change limiter, Switch, Limiter, Constant, AND, OR, Exclusive OR, NOT, Latch, Comparison(=, <, >, ≤, ≥), Not equivalent, Within range, AND(word), OR(word), Shift word, Sum, Timer, Ten-segment linearizer 1/2, Inverse ten-segment linearizer 1/2, Curve linearizer 1/2, Ratio, First order lag filter, Conversion to engineering unit, Selection of PV from two inputs, Temperature and humidity calculation, Fluid Temperature/Pressure compensation, MV selection1/2, Conversion of display value, Parameter setting, Data display1/2, Special discrete output calculation, Assignment of output terminals 1/2, etc.

Maximum Number of Module to be used: 50 for input Custom computation, 50 for output Custom computation

● Display and Operation Function

PV Display Unit

Either PV1 or PV2 can be displayed on 5 digit digital display unit and switched one from the other.

(Digit of display: 4 or 5 digit) For Thermocouple and RTD input, the display of the digits lower than decimal point can be off.

The display range is -19999 to 30000 and the display span is 30000 or less. [750.00 appearing in the product photograph on page 1 cannot actually be displayed.]

LCD Display Unit

Some data are displayed on LCD display unit. Each screen is called "display".

Five types of display are provided; Operating display, Operating parameter setting display, Program parameter setting display, Setup parameter setting display and SELECT display.

Each screen of LCD display unit contains: Operating display: Necessary data for operation is displayed according to UP mode. Such items as Program pattern, Setpoint, Control output, control output bar, deviation trend, is displayed. Time base of deviation trend is 120 s to 20 h.

Operating parameters setting display: The Operating parameters, which are mainly changed during operation, such as PID constant, are displayed. The explanation of each parameters is provided.

Program Parameters Setting display: Generation of Program pattern, and parameters for Wait Function and Repeat Function are displayed.

Setup parameter setting display: The Setup parameters to configure functions of the instrument before starting operation are displayed. The explanation of each parameters is provided.

SELECT display: Up to 5 displays which are frequently accessed can be selected from Operating parameter setting display and Setup parameters setting display.

Status Lamps

Event indicating lamp: 7 points (TME1, TME2, TME3, TME4, PVE1, PVE2, AL)

Operation mode indicating lamp: PRG (Program operation), RST (Program operation reset), HLD (Program operation hold), LOC (Local operation), MAN1 (Loop1 in Manual mode), MAN2 (Loop2 in Manual mode), CAS (Cascade operation).

Operation Key

▲, ▼ key: Increase/decrease the value of Setpoint or other parameters which appear on LCD display.

DISP key: Switch data to be showed on LCD display

SET/ENT key: Set/change the setting value, switch information to be showed on LCD display, switch operation mode other than AUTO/MAN.

▽ PT No. Δ key: Select program pattern No.

RUN key: Start the program operation

RESET key: Stop and reset the program operation.

Security Function

Key lock from parameters setting and, operation can be inhibited by a password.

● Communication Functions

(For UP750-□1 only)

The instrument allows two communication ports and five types of communication protocols, and allows the simultaneous communication with two different instruments. The instruments to communicate are such as a personal computer, a programmable logic controller, other UT750/UP750, and Digital I/O expansion module.

Communication Protocol

Computer link communication: Communication protocol with a personal computer, PLC communication modules, and more.

Ladder communication (BCD serial communication): Communication protocol with the ladder program on some programmable logic controllers.

MODBUS communication: Communication protocol with a personal computer or PLC.

Coordinated operation protocol: Protocol to realize Coordinated operation with other GREEN SERIES controller. UP750 is always configured as a master unit.

Digital input/output expansion(μ -Bus): Protocol to connect Digital I/O expansion module to increase the number of Discrete Input and Output.

RS-485 Communication Interface

Two types of RS-485 communication interface(conforms to EIA RS485) are available; High performance interface and general purpose interface. Both interfaces are available simultaneously according to usage.

High Performance Interface:

High performance RS-485 communication is available with Computer link, Ladder, Digital I/O expansion module, and Coordinated operation communication.

Specification (Common for Computer link, Ladder, and Coordinated operation):

- Maximum number of connectable controllers: 31 units max.
- Maximum communication distance: 1,200 m max.
- Communication method: 2 wire, half duplex, Start-stop synchronization system, Protocol free
- Communication rate: 600, 1200, 2400, 4800, 9600bps, 19.2k, 38.4kbps.

Digital I/O Expansion Module Communication (μ -Bus):

Digital I/O Expansion module communication terminals are same as high performance communication terminals.

Digital I/O Expansion module: P2ER1-20J, P2ET1-20J, P2 ER6-20J, P2ET6-20J

- Units to be connected: 2 units max.
- Maximum communication distance: 15m max.
- Communication rate: 1.25Mbps

General Purpose Interface:

General purpose communication is interface available with Computer link, Ladder or Coordinated operation.

Specification (Common for Computer link, Ladder, and Coordinated operation)

- Maximum number of connectable controllers: 31 units max.
- Maximum communication distance: 1200 m
- Communication method: Two-wire half duplex or four-wire half duplex Start-stop synchronizations system, Protocol free
- Communication rate: 600, 1200, 2400, 4800, 9600 bps

Status lamps
Second PV(PV2)
Time event(TME1 to 4), PV event(PVE1/2), alarm(AL1), Program operation(PROG), Reset(RST), Hold(HLD), Local operation(LOC), Loop 1 in Manual operation (MAN1), Loop 2 in Manual operation(MAN2), Cascade operation(CAS)

Communication port for light loader
Communicate with personal computer to transfer the parameter/program setting data and Custom computation data.

Operational keys
Increase/Decrease the setting data(\blacktriangle , \blacktriangledown)
Transfer the display(DISPLAY), Operation mode selection(MODE), Setting Parameters/values(SET/ENT)
Program pattern selection(Δ PT No. ∇), Program operation Start(RUN), Program operation reset(RESET)



PV display unit
Display PV.
Error code is displayed when error is detected.

LCD display unit
Display setting item and setting data of Setpoint(SP), program pattern, output opening, deviation bar-graph, deviation value, deviation trend, parameter, etc.

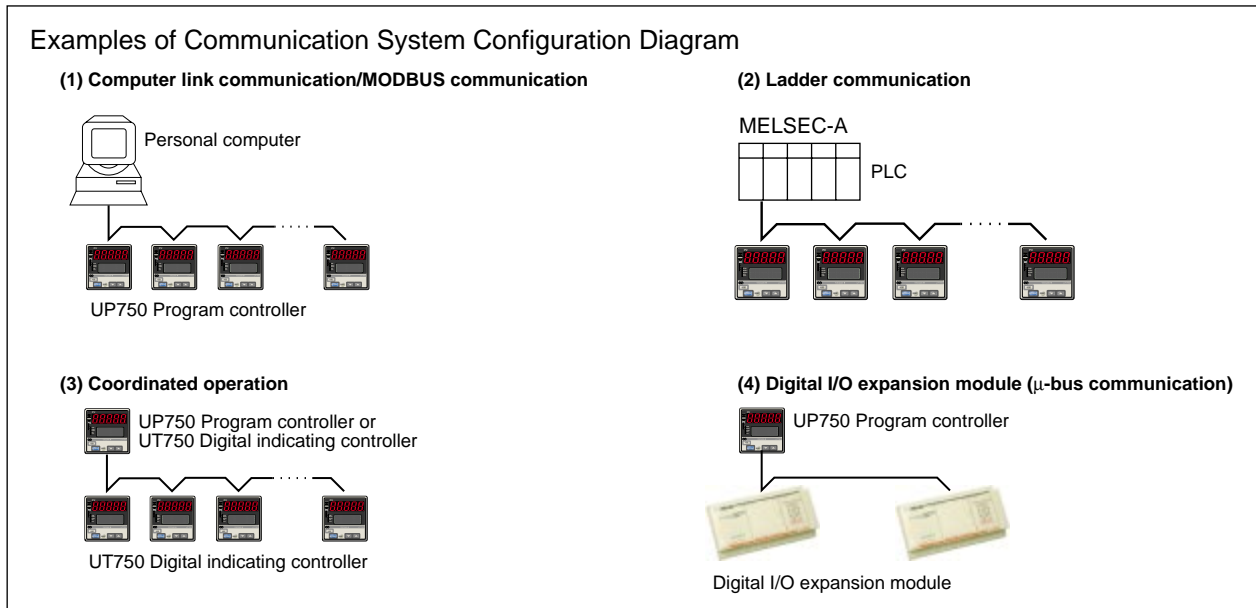

■ Hardware specifications

● Input/Output Signal Specifications

Measured Input Signal

Number of input: 1 or 2 points
 Input type, measurement input range and measurement accuracy:
 Refer to the table below.
 Possible to select input type/measurement range by software.
 Sampling period: 100, 200 or 500 ms (selectable) (default: 200 ms)
 Burnout detection: Available with Thermocouple, RTD, standard signal 0.4 to 2 V DC and 1 to 5 V DC input. Possible to specify a travel of upscale, downscale or off.
 For DC voltage input, 0.1 V or less are regarded as burnout.

Input bias current: 0.05 μ A (For T/C and RTD b-terminal)
 Specified current (RTD): about 0.13 mA
 Input resistance: TC/mV input 1 M Ω or more
 DC Voltage input approx. 1 M Ω (approx. 8 M Ω for range 0.0 to 1.2 V of measuring input 2)
 Allowable signal source resistance:
 TC/mV input: 250 Ω or less: Effect from allowable signal source resistance 0.1 μ V/ Ω or less
 DC Voltage input: 2 k Ω or less: Effect from allowable signal source resistance 0.01%/100 Ω or less
 Allowable leadwire resistance (for RTD input): Maximum 150 Ω /one wire (Lead resistances of three wires must be equal.)
 However, it must be 10 Ω /one wire for the range of -150.0 to 150.0 $^{\circ}$ C.
 Effect of wiring resistance: $\pm 0.1^{\circ}$ C/10 Ω

Input type	Input range code	Instrument range ($^{\circ}$ C)	Instrument range ($^{\circ}$ F)	Instrument accuracy*1	
Unspecified (When shipped from the factory)	OFF	Set the data item PV input type "IN 1" or "IN 2" to the OFF option to leave the PV input type undefined.			
Thermocouple	K	typeK1 (1)	-200.0 to 1370.0 $^{\circ}$ C	-300.0 to 2500.0 $^{\circ}$ F	$\pm 0.1\%$ ± 1 digit of instrument range at 0 $^{\circ}$ C or more $\pm 0.2\%$ ± 1 digit of instrument range at less than 0 $^{\circ}$ C
		typeK2 (2)	-200.0 to 1000.0 $^{\circ}$ C	0.0 to 2300.0 $^{\circ}$ F	
		typeK3 (3)	-200.0 to 500.0 $^{\circ}$ C	-200.0 to 1000.0 $^{\circ}$ F	
	J	typeJ (4)	-200.0 to 1200.0 $^{\circ}$ C	-300.0 to 2300.0 $^{\circ}$ F	$\pm 0.15\%$ ± 1 digit of instrument range at 400 $^{\circ}$ C or more $\pm 5\%$ ± 1 digit of instrument range at less than 400 $^{\circ}$ C
	T	typeT1 (5)	-200.0 to 400.0 $^{\circ}$ C	-300.0 to 750.0 $^{\circ}$ F	
		typeT2 (6)	0.0 to 400.0 $^{\circ}$ C	-200.0 to 750.0 $^{\circ}$ F	$\pm 0.15\%$ ± 1 digit of instrument range
	B	typeB (7)	0.0 to 1800.0 $^{\circ}$ C	32 to 3300 $^{\circ}$ F	
	S	typeS (8)	0.0 to 1700.0 $^{\circ}$ C	32 to 3100 $^{\circ}$ F	$\pm 0.1\%$ ± 1 digit of instrument range $\pm 0.25\%$ ± 1 digit of instrument range for temperature at less than 0 $^{\circ}$ C
	R	typeR (9)	0.0 to 1700.0 $^{\circ}$ C	32 to 3100 $^{\circ}$ F	
	N	typeN (10)	-200.0 to 1300.0 $^{\circ}$ C	-300.0 to 2400.0 $^{\circ}$ F	$\pm 0.1\%$ ± 1 digit of instrument range for temperature at 0 $^{\circ}$ C or more $\pm 0.2\%$ ± 1 digit of instrument range for temperature at 0 $^{\circ}$ C or more
	E	typeE (11)	-200.0 to 1000.0 $^{\circ}$ C	-300.0 to 1800.0 $^{\circ}$ F	
	L (DIN)	typeL (12)	-200.0 to 900.0 $^{\circ}$ C	-300.0 to 1600.0 $^{\circ}$ F	$\pm 0.2\%$ ± 1 digit of instrument range
	U (DIN)	typeU1 (13)	-200.0 to 400.0 $^{\circ}$ C	-300.0 to 750.0 $^{\circ}$ F	
		typeU2 (14)	0.0 to 400.0 $^{\circ}$ C	-200.0 to 1000.0 $^{\circ}$ F	$\pm 0.2\%$ ± 1 digit of instrument range
W (DIN)	typeW (15)	0.0 to 2300.0 $^{\circ}$ C	32 to 4200 $^{\circ}$ F		
Platinel 2	plati2 (16)	0.0 to 1390.0 $^{\circ}$ C	32.0 to 2500.0 $^{\circ}$ F	$\pm 0.1\%$ ± 1 digit of instrument range $\pm 0.5\%$ ± 1 digit of instrument range at 800 $^{\circ}$ C or more Accuracy not guaranteed for temperature less than 800 $^{\circ}$ C	
PR20-40	PR2040 (17)	0.0 to 1900.0 $^{\circ}$ C	32 to 3400 $^{\circ}$ F		
W97Re3-W75Re25	W97Re3 (18)	0.0 to 2000.0 $^{\circ}$ C	32 to 3600 $^{\circ}$ F	$\pm 0.2\%$ ± 1 digit of instrument range	
RTD	JPt100	JPt1 (30)	-200.0 to 500.0 $^{\circ}$ C	-300.0 to 1000.0 $^{\circ}$ F	$\pm 0.1\%$ ± 1 digit of instrument range (Note 1) (Note 2)
		JPt2 (31)	-150.00 to 150.00 $^{\circ}$ C	-200.0 to 300.0 $^{\circ}$ F	
	Pt100	Pt1 (35)	-200.0 to 850.0 $^{\circ}$ C	-300.0 to 1560.0 $^{\circ}$ F	$\pm 0.1\%$ ± 1 digit of instrument range (Note 1) (Note 2)
		Pt2 (36)	-200.0 to 500.0 $^{\circ}$ C	-300.0 to 1000.0 $^{\circ}$ F	
		Pt3 (37)	-150.00 to 150.00 $^{\circ}$ C	-200.0 to 300.0 $^{\circ}$ F	
Standard signal	0.4 to 2V	0.4 to 2V (40)	0.400 to 2.000 V	Display range: -19999 to 30000 Display span: 30000 or less (Decimal point position changeable)	$\pm 0.1\%$ ± 1 digit of instrument range
	1 to 5V	1 to 5V (41)	1.000 to 5.000 V		
DC voltage	0 to 2V	0 to 2V (50)	0.000 to 2.000 V		
	0 to 10V	0 to 10V (51)	0.00 to 10.00 V		
	0.0 to 1.2 V (Note 3)	0.00 to 1.25 V(52)	0.000 to 1.250 V		
	-10 to 20mV	mV1 (55)	-10.00 to 20.00 mV		
	0 to 100mV	mV2 (56)	0.0 to 100.0 mV		

Numbers in () are the measurement input range codes that apply when the communication function is used.

*1: Performance in the standard operating conditions (at 23 $\pm 2^{\circ}$ C, 55 $\pm 10\%$ RH, and 50/60Hz power frequency)

Note 1 : The accuracy is $\pm 0.3^{\circ}$ C of instrument range ± 1 digit for a temperature range from 0 to 100 $^{\circ}$ C

Note 2 : The accuracy is $\pm 0.5^{\circ}$ C of instrument range ± 1 digit for a temperature range from -100 to 200 $^{\circ}$ C.

Note 3 : Available for only measurement input 2.

Allowable input voltage:
 TC/mV/RTD: ± 10 VDC
 DC Voltage: ± 20 VDC
 Noise rejection ratio:
 Normal mode: 40dB(50/60Hz) or more
 Common mode: 120dB(50/60Hz) or more
 RJC Error: $\pm 1.0^\circ\text{C}$ (15 to 35°C),
 $\pm 1.5^\circ\text{C}$ (0 to 15°C , 35 to 50°C)
 Applicable standard:
 TC/RTD: JIS/IEC/DIN (ITS-90)

Auxiliary Analog Input

(For UP750- □ 1 only)
 Functions: Remote setpoint input, compensatory input,
 PV input of Cascade secondary-loop, etc.
 Input type: DC voltage input 0 to 2 V DC, 0 to 10 V DC,
 0.4 to 2.0 V DC or 1 to 5 V DC (Settable
 within the range)
 Number of input: 1 point
 Sampling period: 100, 200 or 500 ms
 auxiliary analog input period is linked with
 PV sampling period.
 Input resistance: Approx. $1\text{M}\Omega$
 Input accuracy: $\pm 0.3\% \pm 1$ digit of F.S.
 for 0 to 2 V DC range
 $\pm 0.2\% \pm 1$ digit of F.S. for 0 to 10 V DC range
 $\pm 0.375\% \pm 1$ digit of F.S. for 0.4 to 2.0 V DC
 range.
 $\pm 0.3\% \pm 1$ digit of F.S. for 1 to 5 V DC range.
 Performance in the standard operating
 conditions (at $23 \pm 2^\circ\text{C}$, $55 \pm 10\%$ RH, and 50/
 60 Hz power frequency)

Retransmission Output

Any of the PV, target setpoint or control output is output.
 Can be used as the 15 V DC loop power supply.
 Number of output points: 1 or 2
 Retransmission output 2 is available only
 when "relay" is selected as the control output
 function.
 Output signal: 4 to 20 mA DC, 0 to 20 mA DC, 20 to 4
 mA DC or 20 to 0 mA DC (0 mA or less
 cannot be output)
 Load resistance: $600\ \Omega$ or less
 Output accuracy: $\pm 0.1\%$ of span ($\pm 5\%$ for 1 mA or less)
 Performance in the standard operating
 conditions (at $23 \pm 2^\circ\text{C}$, $55 \pm 10\%$ RH, and 50/
 60 Hz power frequency)

When using for 15 V DC loop power supply:

Supply voltage 14.5 to 18.0 V DC, maximum supply
 current about 21 mA (with the protection
 circuit at field short-circuit)

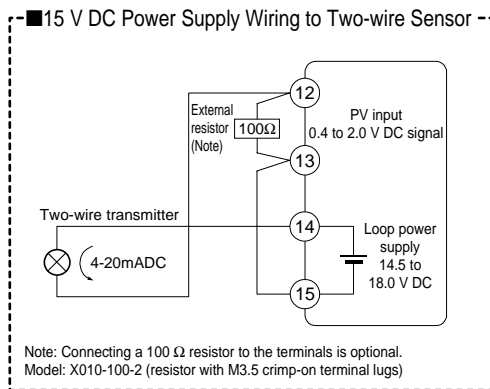

Control Outputs

One or two points can be selected from the following types,
 according to the model codes and specified UP mode.

Current output:
 Number of output: 1 or 2 points (for heating/cooling type)
 (selected between voltage pulse output)

Output signal: 4 to 20 mA DC, 0 to 20 mA DC, 20 to 4 mA
 DC or 20 to 0 mA DC
 Load resistance: $600\ \Omega$ or less
 Output accuracy: $\pm 0.1\%$ of output span ($\pm 5\%$ for 1 mA or
 less)
 Performance in the standard operating
 conditions (at $23 \pm 2^\circ\text{C}$, $55 \pm 10\%$ RH, and
 50/60 Hz power frequency)

Voltage pulse output:
 Number of output: 1 or 2 points (for heating/cooling
 type) (selected between current output)
 Output signal: ON voltage 12 V DC or more (lead
 resistance $600\ \Omega$ or less), OFF voltage 0.1
 V DC or less
 Resolution: 10ms or 0.1% of output value, whichever is
 greater
 Relay contact output:
 Number of output: 1 or 2 points (for heating/cooling
 type)
 Output signal: Three terminals (NC, NO, and common)
 Contact rating: 250 V AC 3 A or 30 V DC 3 A (Load
 resistance)
 Resolution: 10ms or 0.1% of output value, whichever is
 greater

Contact Inputs

Usage: Program pattern switching, Local/Remote
 switching, HOLD, ADVANCE selection,
 RUN/RESET switching, measured input
 selection, and message interruption display.
 Number of input: 7 points (23 points max. when using
 Digital I/O expansion module).
 Input type: Non-voltage contact input or transistor open
 collector input
 Input contact rating: 12 V DC, 10mA or more
 ON/OFF detection:
 For non-voltage contact contact input:
 ON=contact resistance 1 k Ω or less,
 OFF=contact resistance 20 k Ω or more
 For transistor input:
 ON=2 V or less,
 OFF=leak current 100 μA or less
 Minimum detecting time: PV input sampling period $\times 3$

Contact Outputs

Usage: Instrument alarm output, Cooling side output
 for Heating/Cooling control (Transistor
 contact output), Event output.
 Number of output: 7 points (Relay output 3 points, Open
 collector output 4 points), (23 points max.
 when using Digital I/O expansion module).
 Relay contact rating: 240 V AC 1 A or 30 V DC 1 A
 (Common to COM terminal)
 Transistor contact rating: 24 V DC 50 mA (Common to
 COM terminal)

Expansion Digital I/O

Up to two Digital I/O expansion modules can be connected
 to increase the number of Digital I/O.

Each 8 points of input/output per one module can be
 accessed from the instrument.

Display Specifications

Measured value (PV) display: 5 digit seven segment red
 color LED display, height of a letter: 20 mm
 Data display: 32 \times 128 dot LCD display with back-light
 Status indicating lamp: LED

● Conformance to Safety and EMC standards

Safety: Compliant with IEC/EN61010-1: 2001, approved by CSA1010, approved by UL508.
 Installation category : CAT. II (IEC/EN61010, CSA1010) Pollution degree : 2 (IEC/EN61010, CSA1010)
 Measurement category : I (CAT. I : IEC/EN61010)
 Rated measurement input voltage : 10V DC max.(across terminals), 300V AC max.(across ground)
 Rated transient overvoltage : 1500V (Note)
 Note : It is a value on the safety standard which is assumed by IEC/EN61010-1 in measurement category I, and is not the value which guarantees an apparatus performance.

EMC standards: Complies with EN61326
 During test, the controller continues to operate with the measurement accuracy within $\pm 20\%$ of the range.

● Construction, Installation, and Wiring

Structure: Dust-proof and Drip-proof front panel conforming to IP55.
 For side-by-side close installation, controller loses its dust-proof and drip-proof protection.

Material of the body: ABS resin and polycarbonate

Case color: Black

Weight: Approx. 1 kg or less

Dimensions: 96W×96H×100D (From the front panel surface) (mm)

Mounting: Direct panel mounting; mounting bracket, one each for upper and lower mounting

Panel cutout dimensions: $92^{+0.8}_0$ W × $92^{+0.8}_0$ H (mm)

Mounting position: 0° to +30° with respect to vertical panel surface.

Wiring: M3.5 screw terminal (signals, power supply/ground)

● Power Supply and Isolation

Power supply: Rated voltage 100 to 240V AC, ($\pm 10\%$), 50/60Hz

Power consumption: MAX. 20VA (MAX. 8.0W)

Memory backup: Lithium Battery, Life Time approx. 10years

Withstanding voltage:

Between primary terminal and secondary terminal:
1500V AC for 1 min.

Between primary terminal and ground terminal:
1500V AC for 1 min.

Between ground terminal and secondary terminal:
1500V AC for 1 min.

Between two secondary terminal:
500V AC for 1 min.

(primary terminal: Power supply, Relay output
 secondary terminal: Analogue input/output, Voltage pulse output, contact input.)

Isolation Resistance:

Between power supply terminal and ground
500V DC 20M Ω or more

Grounding: Class D grounding (grounding resistance of 100 Ω or less)

Isolation Specifications

Measured input terminal 1: Isolated from Measured input terminal 2 and other input/output terminals.
Not isolated from internal circuits.

Measured input terminal 2: Isolated from Measured input terminal 1, other input/output terminals and internal circuits.

Auxiliary analogue input terminal: Isolated from other input/output terminals and internal circuits.

Control output (current output or voltage pulse output) and retransmission output: Not isolated between control output and retransmission output terminals. Isolated from other input/output terminals and internal circuits.

Relay contact control output terminals: Isolated from other input/output terminals and input circuits.

Contact input terminals: Not isolated from other contact input and communication terminals.
Isolated from other input/output terminals and internal circuits.

Relay contact event output terminals: Isolated from other input/output terminals and internal circuits.

Transistor contact event output terminals: Not isolated between other open collector output terminals mutually. Isolated from other input/output terminals and internal circuits.

RS-485 communication terminals: Not isolated between other communication terminals, and from contact input terminals. Isolated from other input/output terminals and internal circuits.

Power supply terminals: Isolated from other input/output terminals and internal circuits.

Ground terminal: Isolated from other input/output terminals and internal circuits.

● Environmental Conditions

Normal operating conditions:

Ambient temperature: 0 to 50°C 40°C or less in close mounting side-by-side.

Temperature change rate limit: 10°C/h or less

Ambient humidity: 20 to 90%RH (no condensation)

Ambient humidity: 20 to 90%RH (no condensation)

Magnetic field: 400 A/m or less

Continuous vibration (5 to 14Hz): amplitude 1.2mm or less

Continuous vibration (14 to 150Hz): 4.9m/s² or less

Vibration in short period: 14.7m/s², 15sec or less

Shock: 147m/s² or less, 11ms

Installation altitude: 2000m above the sea level or less

Warm-up time: 30 minutes or more

Transit/storage conditions:

Temperature: -25 to 70°C

Temperature change rate limit: 20°C/h or less

Humidity: 5 to 95%RH (non-condensing)

Effects of operating conditions:

Effect of ambient temperature:

For Voltage/TC input: Within ($\pm 1\mu\text{V}/^\circ\text{C}$ or $\pm 0.01\%$ of F.S./ $^\circ\text{C}$, whichever is greater.)

For Auxiliary input: Within $\pm 0.02\%$ of F.S./ $^\circ\text{C}$

For RTD input: Within $\pm 0.05^\circ\text{C}/^\circ\text{C}$ (ambient temperature)

For analog output: Within $\pm 0.05\%$ of F.S./ $^\circ\text{C}$

Effect of power supply fluctuation (within rating voltage):

For analog input: Within ($\pm 1\mu\text{V}/10\text{V}$ or $\pm 0.01\%$ of F.S./10V, whichever is greater.)

For analog output: Within $\pm 0.05\%$ of F.S./10V

Function Block Diagram for Single-loop Control

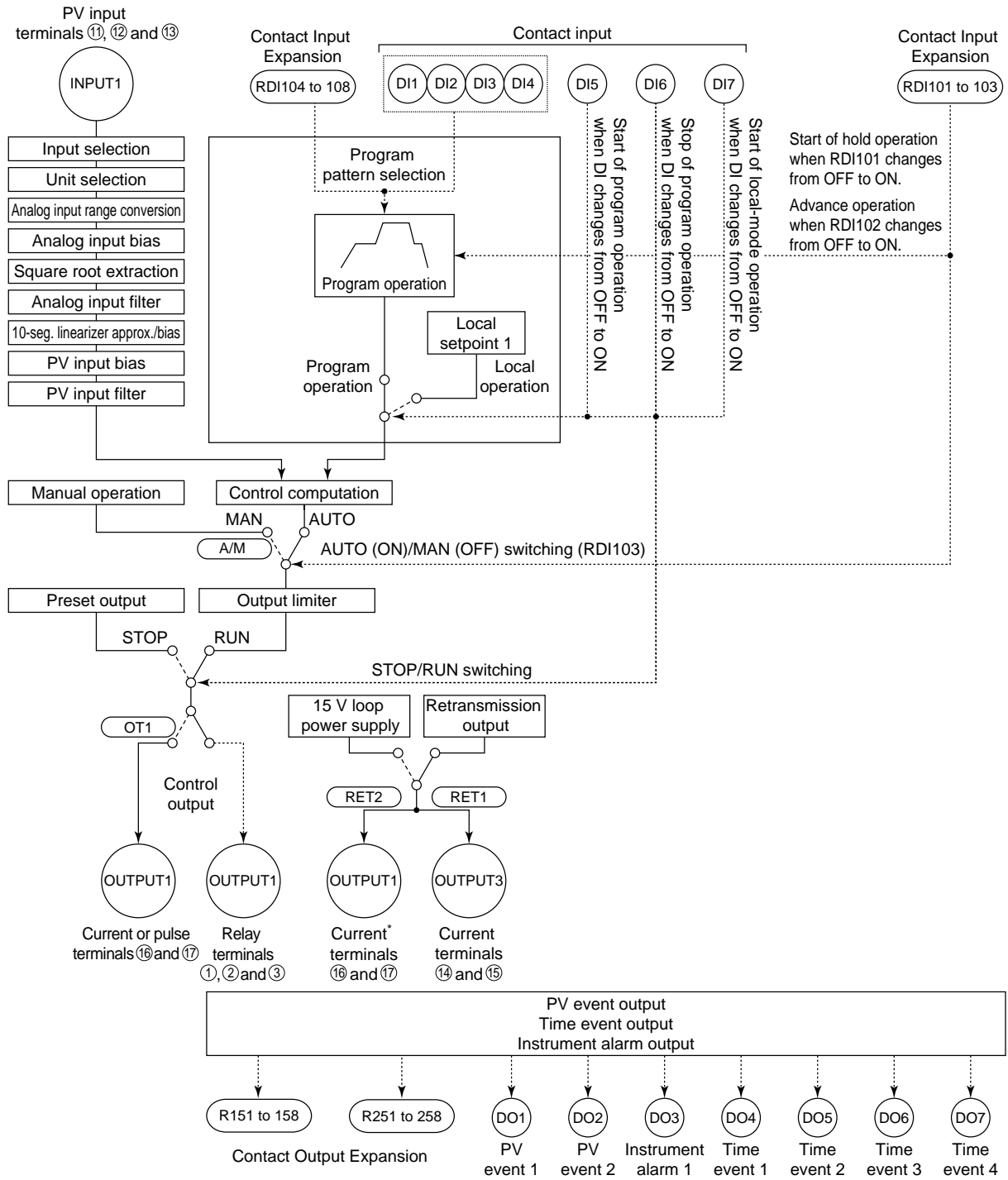

* Unavailable when control output is current or pulse.

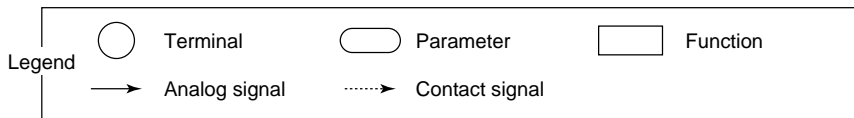

■ Function Block Diagram for Custom Computation

The UP750 controller comes with built-in control functions and various controller modes (UP modes) that provide different I/O computing functions. These modes are designed to support their respective control applications. From these choices, you can choose one that best meets your application needs.

In some control applications, however, you may want to execute special computations based upon specific input data or have a contact output of a specific data item in a specific control sequence. To be able to meet these needs, the UP750 controller provides a separate controller mode with which you can freely program your own computations. Computing functions available in these modes are referred to as custom computations.

Custom computations allow you to perform a variety of calculations based on input and output signals. These calculations include not only the four arithmetic operations and logical operations but also ten-segment linear approximations, temperature and humidity computations, temperature-based correction coefficient computations, pressure-based correction coefficient computations, and so on.

For example, you can use the four arithmetic operations to apply the desired type of correction to input signals, or use a logical operation to program a sequencing process that works between input and output contacts.

Custom computations are configured using the given methods of block connection, as shown in Figures below.

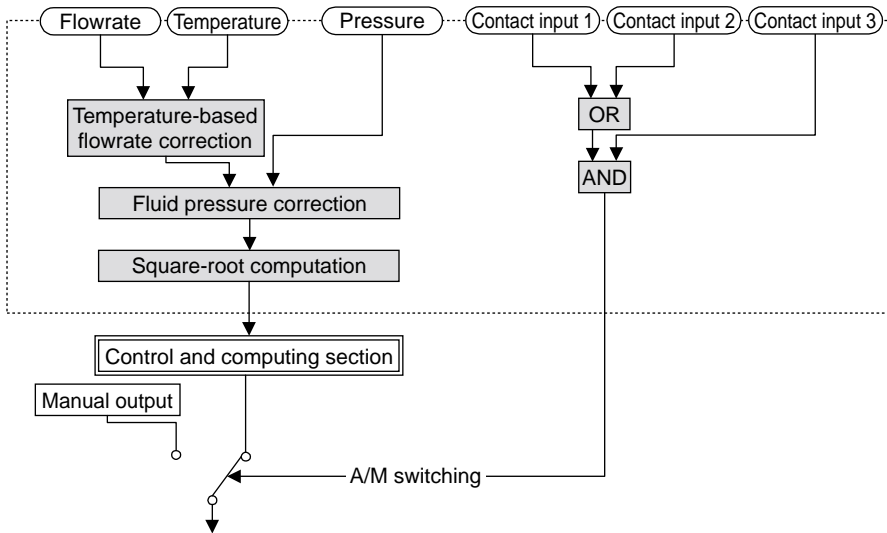

Custom Computations Applied to Input Signals

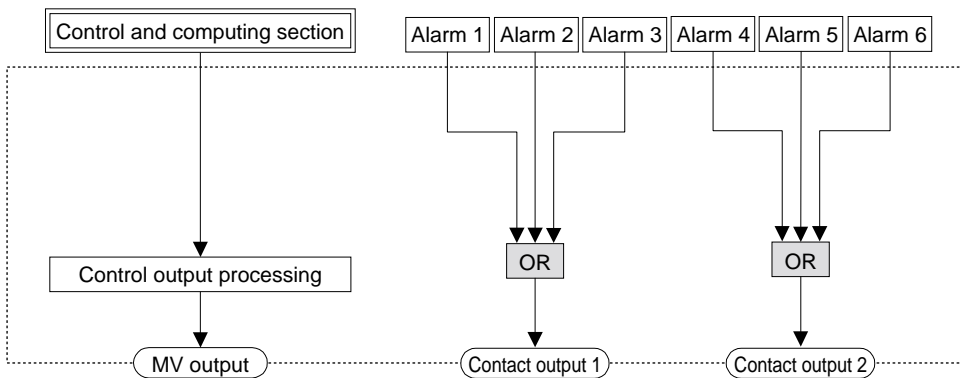

Custom Computations Applied to Output Signals

■ UP750 Single-loop Control (Model UP750-0□ or UP750-5□)

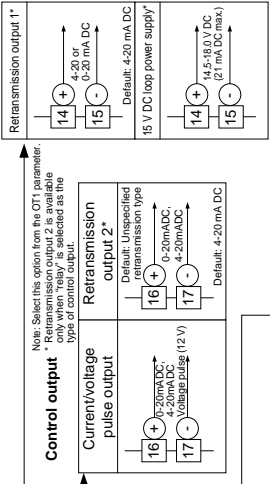
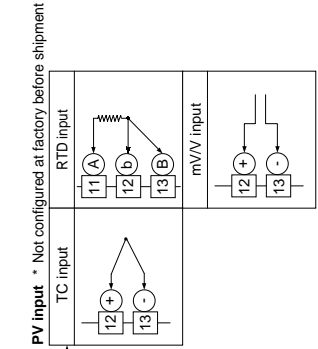
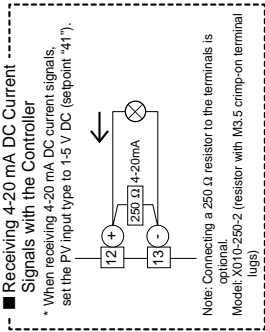
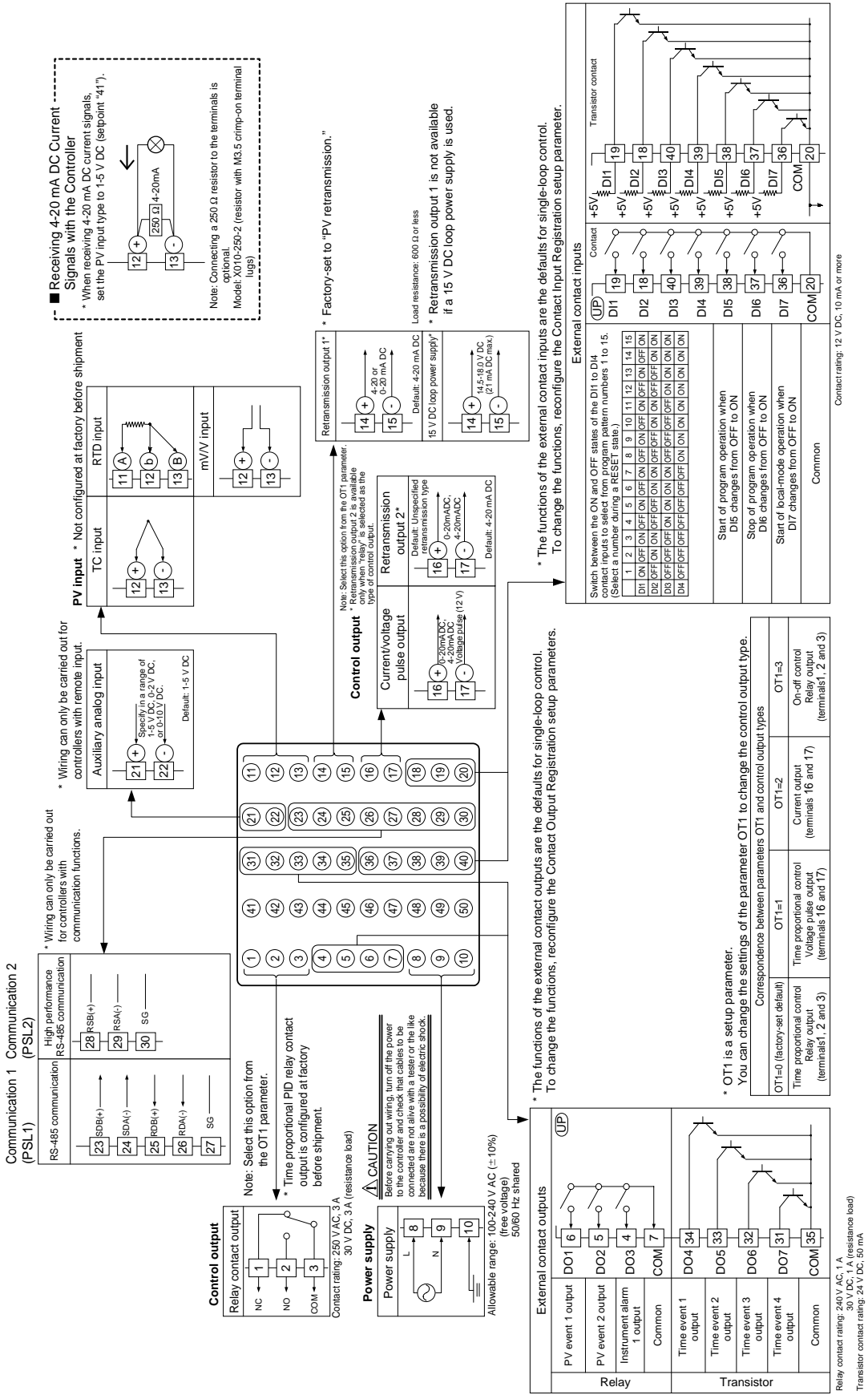

* The functions of the external contact outputs are the defaults for single-loop control. To change the functions, reconfigure the Contact Output Registration setup parameters.

* The functions of the external contact inputs are the defaults for single-loop control. To change the functions, reconfigure the Contact Input Registration setup parameter.

* Wiring can only be carried out for controllers with remote input.

* Wiring can only be carried out for controllers with communication functions.

Note: Select this option from the OT1 parameter.

* Time proportional PID relay contact output is configured at factory before shipment.

CAUTION

Before carrying out wiring, turn off the power to the controller and check that cables to be connected are not alive with a tester or the like because there is a possibility of electric shock.

* OT1 is a setup parameter. You can change the settings of the parameter OT1 to change the control output type. Correspondence between parameters OT1 and control output types

OT1=0 (factory-set default)	OT1=1	OT1=2	OT1=3
Time proportional control Relay output (terminals 1, 2 and 3)	Time proportional control Voltage pulse output (terminals 16 and 17)	Current output (terminals 16 and 17)	On-off control Relay output (terminals 1, 2 and 3)

External Dimensions and Panel Cutout Dimension

Unit: mm

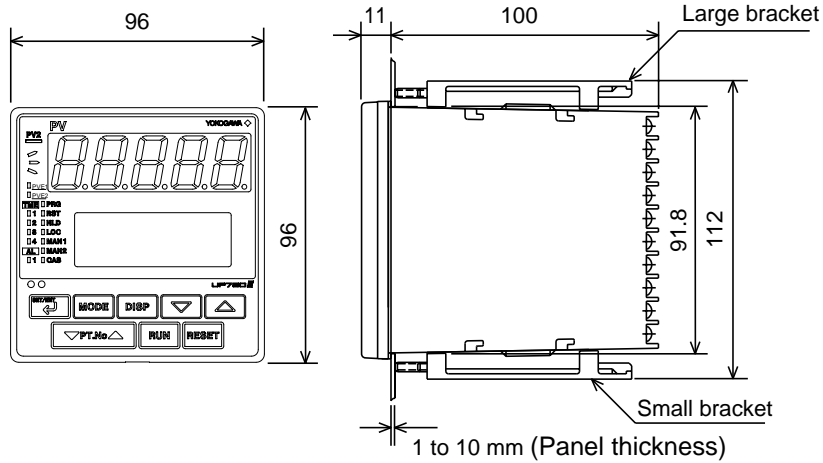

General installation

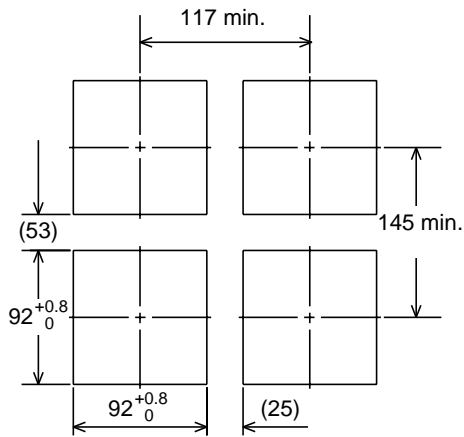

Side-by-side close installation

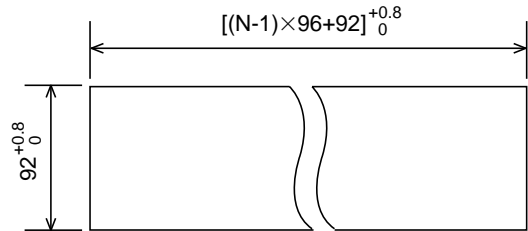

“N” stands for the number of controllers to be installed.
However, the measured value applies if $N \geq 5$.

■ Model and Suffix codes

Model	suffix code	Discription
UP750		Program controller (provided with Custom Computing Function ^{*Note*})
Type	-0	Single-loop type
	-5	Dual-loop type
Optional Functions	0	None
	1	With communication, auxiliary analog input

Note: Using an optional custom computation building tool (Model LL200-E10) that runs on a personal computer, you can build a variety of computation (e.g., four arithmetic operations, logical operations, ten-segment linearizer computations, temperature compensation factor computations, and pressure compensation factor computations) to be applied to the controller's I/O signals.

Standard accessories: Brackets (mounting hardware), unit label, User's Manuals, and User's Manual (reference) (CD-ROM version).

Specify suffix code according to the designated UP mode.

Correspondence between UP mode and suffix code

UP mode	suffix code →	00	01	50	51	
Single-loop control	(UP mode 1)	App.	App.	App.	App.	
Cascade primary-loop control	(UP mode 2)	N/A	App.	N/A	App.	
Cascade control	(UP mode 4)	N/A	App.	N/A	App.	An auxiliary analog input is used as cascade input.
Loop control with PV switching	(UP mode 6)	N/A	App.	N/A	App.	An auxiliary analog input is used as PV input 2.
Loop control with PV auto-selector	(UP mode 7)	N/A	App.	N/A	App.	An auxiliary analog input is used as PV input 2.
Dual-loop control	(UP mode 11)	N/A	N/A	App.	App.	
Temperature and humidity control	(UP mode 12)	N/A	N/A	App.	App.	
Cascade control with two universal inputs	(UP mode 13)	N/A	N/A	App.	App.	
Loop control with PV switching and two universal inputs	(UP mode 14)	N/A	N/A	App.	App.	
Loop control with PV auto-selector and two universal inputs	(UP mode 15)	N/A	N/A	Cond.	App.	Cond.=Two PV inputs are available. App.=Three PV inputs are available.
Custom computation control	(UP mode 21)	App.	App.	App.	App.	

App: Function available, Cond: Function available conditionally, N/A: Function not available

Digital I/O expansion module

Model	Description
P2ER1-20J*A	AC power supply Inputs (8 points) and relay outputs (8 points)
P2ET1-20J*A	AC power supply Inputs (8 points) and transistor outputs (8 points)
P2ER6-20J*A	DC power supply Inputs (8 points) and relay outputs (8 points)
P2ET6-20J*A	DC power supply Inputs (8 points) and transistor outputs (8 points)

Note 1: Digital I/O expansion modules manufactured by Yokogawa Electric Corporation. Please order to Yokogawa Electric Corporation.

Note 2: Digital I/O expansion modules do not have CE/UL marking.

■ Items to be specified when ordering

Model & suffix code, necessary/unnecessary of User's Manual or QIC

